

TRIM PART NUMBER TABLE		
VALVE SIZE	TRIM PART NUMBERS	
	LOOSE	SEGMENTALLY ASSEMBLED
2"	6508000001	6508000011
2-1/2", 3" & 76MM	6508000002	6508000012
4", 6" & 165MM	6508000003	6508000013
FULLY ASSEMBLED PART NUMBER CODE		
65080XYZ00		
(SEE TABLES FOR "X", "Y" & "Z" CODES)		

CONFIGURATION FOR 2" VERSION

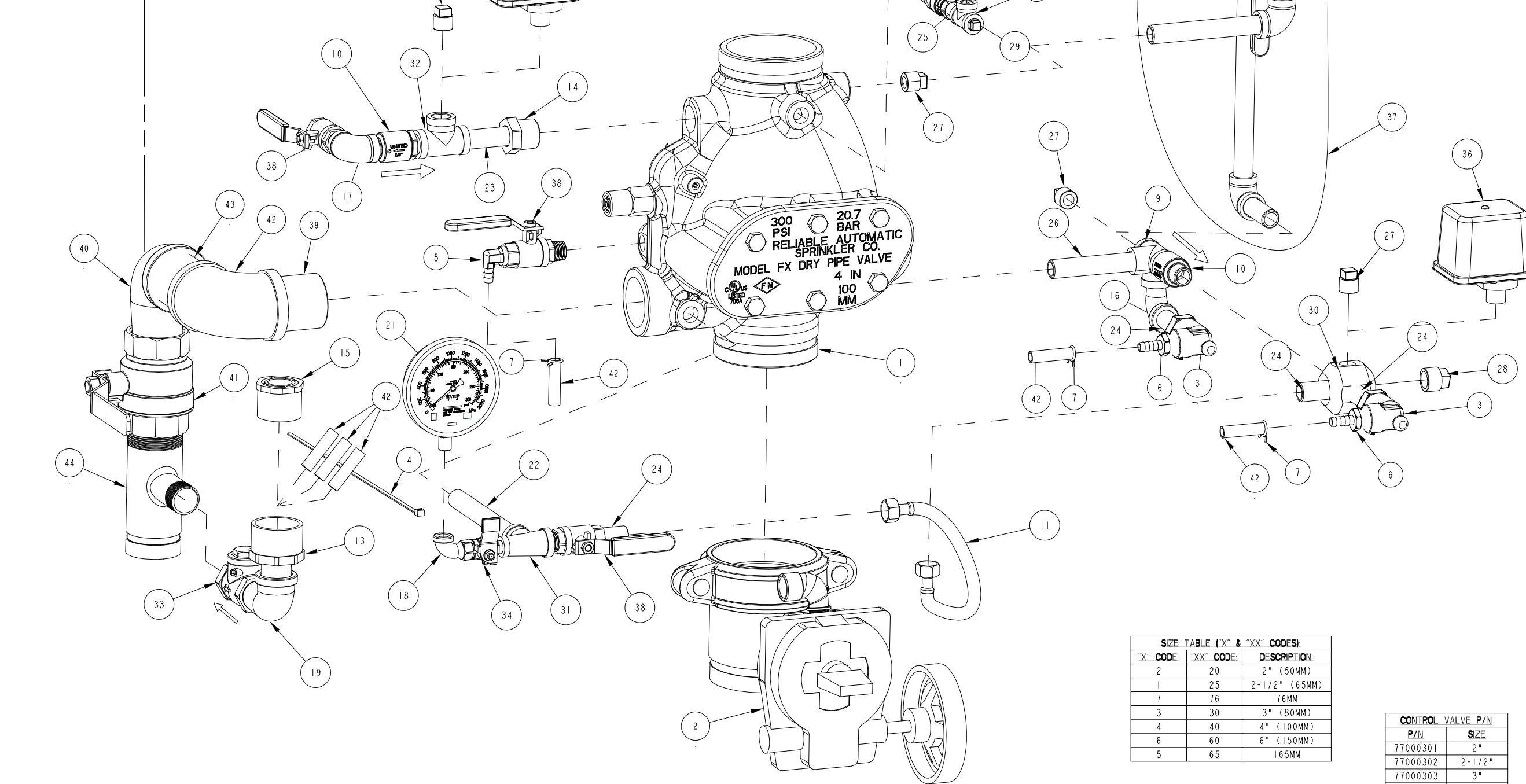
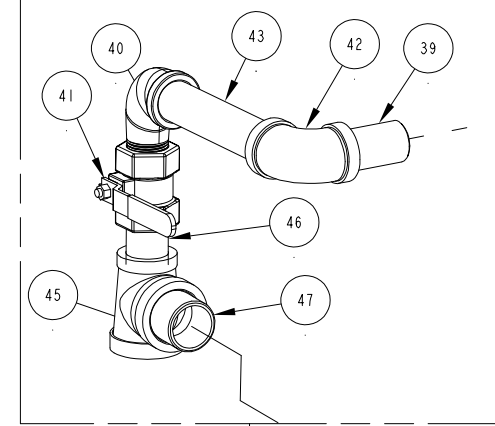

X CODE	XX CODE	DESCRIPTION
2	20	2" (50MM)
1	25	2-1/2" (65MM)
7	76	76MM
3	30	3" (80MM)
4	40	4" (100MM)
6	60	6" (150MM)
5	65	165MM

P/N	SIZE
77000301	2"
77000302	2-1/2"
77000303	3"
77000304	4"
77000306	6"

Y CODE	DESCRIPTION
0	BLACK, GROOVE/GROOVE
1	BLACK, FLANGE/GROOVE, CLASS 150
2	BLACK, FLANGE/GROOVE, BS-E
3	BLACK, FLANGE/GROOVE, PN 16
4	BLACK, FLANGE/FLANGE, CLASS 150
5	BLACK, FLANGE/FLANGE, BS-E
6	BLACK, FLANGE/FLANGE, PN 16
7	RED, GROOVE/GROOVE
8	RED, FLANGE/GROOVE, CLASS 150
9	RED, FLANGE/GROOVE, BS-E
A	RED, FLANGE/GROOVE, PN 16
B	RED, FLANGE/FLANGE, CLASS 150
C	RED, FLANGE/FLANGE, BS-E
E	RED, FLANGE/FLANGE, PN 16

Z CODE	DESCRIPTION
0	W/O CONTROL VALVE, W/O ACCELERATOR
1	W/ CONTROL VALVE, W/O ACCELERATOR
2	W/ 2 CONTROL VALVES, W/O ACCELERATOR
3	W/O CONTROL VALVE, W/ ACCELERATOR
4	W/ CONTROL VALVE, W/ ACCELERATOR
5	W/ 2 CONTROL VALVE, W/ ACCELERATOR

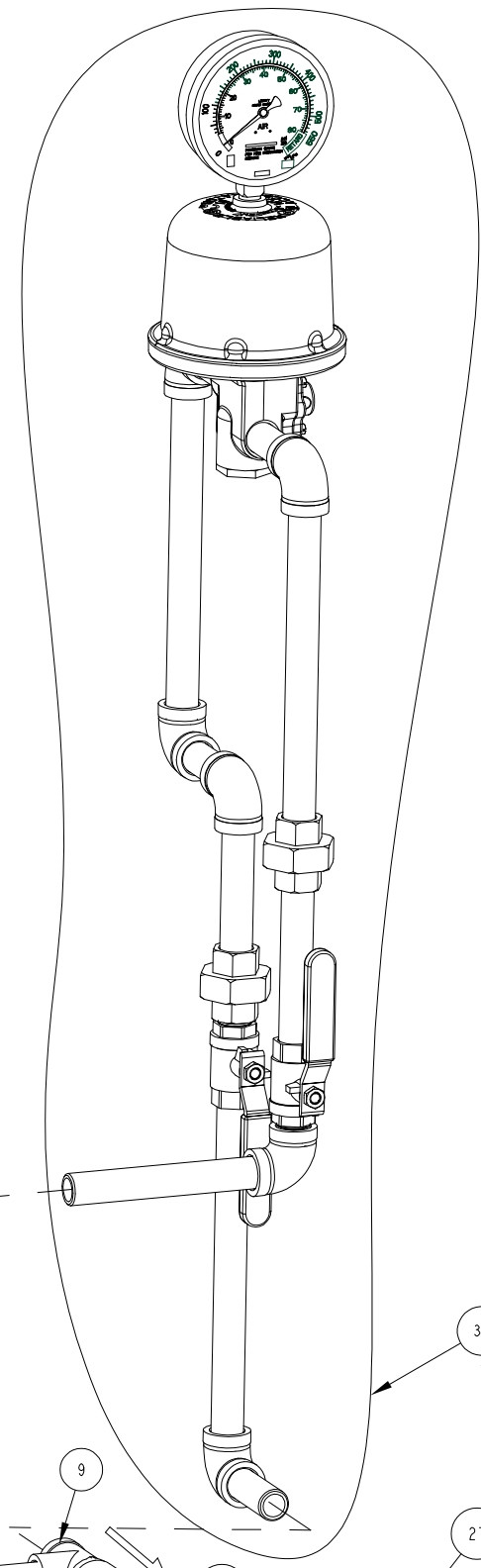

MODEL FX 2", 2-1/2", 3", 4", & 6" DRY PIPE VALVE
CA-327 P/N 89241298 REV. C

ITEM NO	PART NO	DESCRIPTION	REMARKS	QTY
49	95516915	PERMA-LOK	NOT SHOWN	A/R
48	96686756	TUBING, PVC, 3/8" ID, 6FT LONG		1
47	98543213	NIPPLE, STEEL, GALV., 1" X CLOSE	2" VERSIONS	1
46	98543279	NIPPLE, STEEL, GALV., 3/4" X CLOSE	2" VERSIONS	1
45	96606602	TEE, GALV., 1" X 3/4" X 1"	2" VERSIONS	1
44	9101423B	MANIFOLD, 2 X 2 X 1, GRV/THD/THD	4" & 6" VERSIONS	1
	9101423C	MANIFOLD, 1-1/4 X 1-1/4 X 1, GRV/THD/THD	2-1/2" & 3" VERSIONS	
43	98543262	NIPPLE, STEEL, GALV., 2" X 3-1/2"	4" & 6" VERSIONS	1
	98543271	NIPPLE, STEEL, GALV., 1-1/4" X 4-1/2"	2-1/2" & 3" VERSIONS	
42	98543242	NIPPLE, STEEL, GALV., 3/4" X 5"	2" VERSIONS	1
	98174405	ELL, 2", MALL IRON, GALV.	4" & 6" VERSIONS	
41	98174414	ELL, 1-1/4", MALL IRON, GALV.	2-1/2" & 3" VERSIONS	1
	98174402	ELL, 3/4", MALL IRON, GALV.	2" VERSIONS	
40	98840136	VALVE, BALL, 2"	4" & 6" VERSIONS	1
	98840137	VALVE, BALL, 1-1/4"	2-1/2" & 3" VERSIONS	
39	98840108	VALVE, BALL, 3/4"	2" VERSIONS	1
	98174415	ELBOW, STREET, 2" MALL IRON, GALV.	4" & 6" VERSIONS	
38	98174410	ELBOW, STREET, 1-1/4" MALL IRON, GALV.	2-1/2" & 3" VERSIONS	1
	98174413	ELBOW, STREET, 3/4" MALL IRON, GALV.	2" VERSIONS	
37	98543299	NIPPLE, STEEL, GALV., 2" X 2-1/2"	4" & 6" VERSIONS	1
	98543297	NIPPLE, STEEL, GALV., 1-1/4" X 2"	2-1/2" & 3" VERSIONS	
36	98543232	NIPPLE, STEEL, GALV., 3/4" X 2"	2" VERSIONS	1
	9884011A	VALVE, BALL, 1/2 NPTF X 1/2 NPTM		
35	650120001A	ASSEMBLY, TRIM, ACCELERATOR	OPTIONAL	1
34	6990006382	SWITCH, PRESSURE (PS10-2)		1
33	6990006381	SWITCH, PRESSURE (PS40-2)		1
32	98840237	VALVE, BALL, 1/4" NPTF X 1/4" NPTM		2
31	98840145	SWING CHECK VALVE, 1" NPT		1
30	98761651	TEE, 1/2X1/2X1/2, GALVANIZED		1
29	98761649	TEE, 1/2X1/4X1/2, GALVANIZED		1
28	98751005	FITTING, MULTIPOINT, 3/4x1/2x1/2x1/2x1/2		1
27	98614403	PIPE, PLUG, IRON, SQUARE HEAD, 1/4		1
26	98614401	PIPE, PLUG, IRON, SQUARE HEAD, 3/4		1
25	98604406	PIPE, PLUG, IRON, SQUARE HEAD, 1/2		4
24	98543228	NIPPLE, 1/2X4-1/2, GALVANIZED STEEL		1
23	98543227	NIPPLE, 1/4XCLOSE, GALVANIZED STEEL		1
22	98543223	NIPPLE, 1/2X1-1/2, GALVANIZED STEEL		4
21	98543210	NIPPLE, 1/2X2-1/2, GALVANIZED STEEL		1
20	98543203	NIPPLE, 1/2X7, GALVANIZED STEEL		1
19	98248001	GAUGE, WATER PRESSURE (0-300 PSI)		1
18	98248000	GAUGE, AIR PRESSURE (0-80 PSI)		1
17	98174416	ELBOW, STREET, 1", GALV.		1
16	98174408	ELBOW, STREET, 1/4", GALV.		1
15	98174401	ELBOW, 1/2", MALL IRON, GALV.		1
14	98174400	ELBOW, STREET, 1/2", GALV.		1
13	98050006	ADAPTER, PVC, 1-1/2, SOCKET X 3/4 SOCKET		1
12	98048027	BUSHING, REDUCER, 1X1/2, GALVANIZED		1
11	98048017	BUSHING, REDUCER, 1/2X1/4, GALVANIZED		1
10	96920912	FLEX LINE, 12		1
9	96816906	VALVE, CHECK, MALE 1/2, MALE 1/2		2
8	96626902	TEE, SIDE OUTLET, 1/2", 90°, GALV.		1
7	96606608	TEE, 1/4X1/4X1/4, GALVANIZED		1
6	95306255	CLAMP, HOSE, 1/2" CONSTANT TENSION, ZINC		3
5	92056810	CONNECTOR, 3/8" ID TUBE X 1/2" NPT		2
4	92056704	CONNECTOR, ELBOW, 3/8" ID TUBE X 1/2" NPT		1
3	89141112	TIE, RETAINING		1
2	78653800	ASSEMBLY, BALL DRIP, 1/2"		2
1	SEE TABLE	ASSEMBLY, CONTROL VALVE		1 OR 2
1	61010XX60Y	ASSEMBLY, VALVE		1

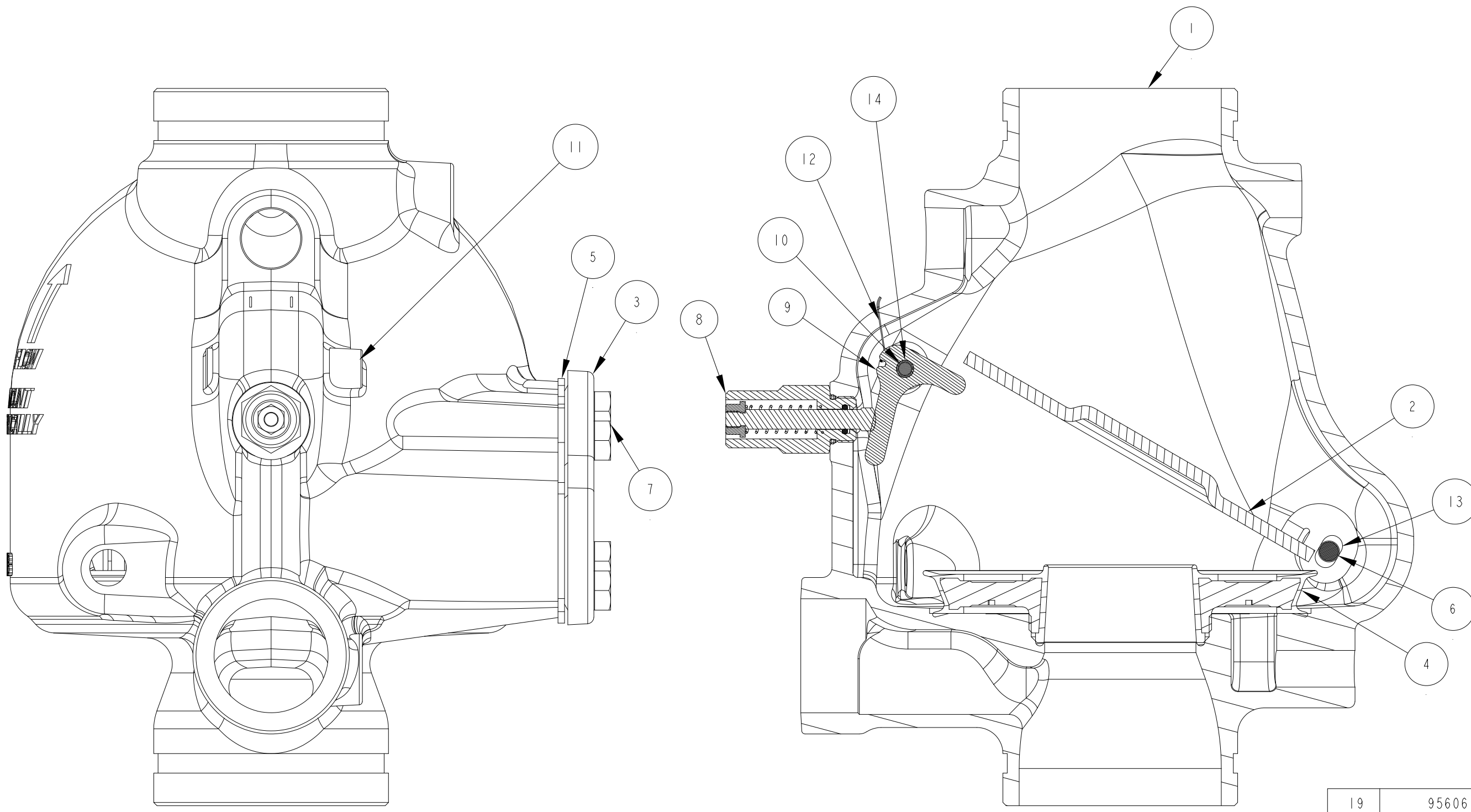

P/N: 6101060600
SECTION A-A

END CONNECTION AND COLOR TABLE ("W" & "Y" CODES):

"W" CODE:	"Y" CODE:	DESCRIPTION:
0	0	BLACK, GROOVE/GROOVE
1	1	BLACK, FLANGE/GROOVE, CLASS 150
2	2	BLACK, FLANGE/GROOVE, BS-E
3	3	BLACK, FLANGE/GROOVE, PN 16
4	4	BLACK, FLANGE/FLANGE, CLASS 150
5	5	BLACK, FLANGE/FLANGE, BS-E
6	6	BLACK, FLANGE/FLANGE, PN 16
7	0	RED, GROOVE/GROOVE
8	1	RED, FLANGE/GROOVE, CLASS 150
9	2	RED, FLANGE/GROOVE, BS-E
A	3	RED, FLANGE/GROOVE, PN 16
B	4	RED, FLANGE/FLANGE, CLASS 150
C	5	RED, FLANGE/FLANGE, BS-E
E	6	RED, FLANGE/FLANGE, PN 16

SIZE TABLE ("XX" & "Z" CODE):

"XX" CODE:	"Z" CODE:	DESCRIPTION:	BOLT P/N:	BOLT DESCRIPTION:	BOLT QTY:	SIZE LABEL	FRICTION LOSS LABEL
20	2	2" (50MM)	95606179	1/2"-13 x 1	4	-	-
25	3	2-1/2" (65MM)	95606179	1/2"-13 x 1	6	94617002	-
76	3	76MM	95606179	1/2"-13 x 1	6	94617004	-
30	3	3" (80MM)	95606179	1/2"-13 x 1	6	94617003	-
40	4	4" (100MM)	95606179	1/2"-13 x 1	6	-	-
60	6	6" (150MM)	95606143	5/8"-11 x 1-1/4"	6	94617006	94617018
65	6	165MM	95606143	5/8"-11 x 1-1/4"	6	94617007	94617018

19	95606185	BOLTS	FOR 6"/165MM ONLY	3
18	92306007	BUMPER	FOR 6"/165MM ONLY	1
17	85000050	GREASE, GPL-201	NOT SHOWN	A/R
16	SEE TABLE	SIZE LABEL	NOT SHOWN	A/R
15	94617000	ADHESIVE, BACKING PAD	FOR USE WITH LABELS	A/R
14	91406261	BUSHING, SPLIT		1
13	98604408	PIPE, PLUG, IRON, HEX, SOCKET, 1/4	NOT SHOWN	1
12	96406330	SPRING, LATCH		1
11	98604409	PIPE, PLUG, IRON, HEX, SOCKET, 1/8	NOT SHOWN	1
10	95000100	PIN, HINGE, 1-1/2, 2		1
9	94446231	LATCH		1
8	94356000	ASSEMBLY, RESET		1
7	SEE TABLE	BOLTS, COVER	QTY, SEE TABLE	A/R
6	96216320	PIN, HINGE		1
5	93716320	GASKET, COVER		1
4	93416220	ASSY, SEAL		1
3	92117020	COVER, MACHINED		1
2	91826220	CLAPPER, PLATED		1
1	91019YXX	BODY, MACHINED		1

BILL OF MATERIALS

ITEM NO.	PART NO.	DESCRIPTION	REMARKS	QTY.
----------	----------	-------------	---------	------

THE RELIABLE AUTOMATIC SPRINKLER CO., INC.
LIBERTY, SC.

PART NO: 61010XX60W DWG SIZE: C
PART: ASSEMBLY, VALVE
PRODUCT: MODEL FX DRY PIPE VALVE

FILE NO: 6101040600	ENG: DD	DRW BY: DD	CK'D:
SCALE: 1:2	DATE: 02/21/17	SHEET 1 of 1	